



**REDERICK**

Rederick Metal Industries Corp. | Miami, FL 33142 | Phone : 305-396-3396 |  
Fax: 305-735-2662 | [customer.service@yardbeast.com](mailto:customer.service@yardbeast.com)



**UNPACKING AND ASSEMBLY MANUAL  
YARDBEAST WOOD CHIPPERS  
(2030RX & 2050RX)**

**UNPACKING & ASSEMBLING YOUR  
WOOD CHIPPER**

# TOOLS AND FASTENERS NEEDED FOR UNPACKING AND ASSEMBLY OF YOUR YARDBEAST

## TOOLS NEEDED:

QTY	TOOL
1	<b>KNIFE</b>
2	<b>7/16" HEX WRENCH</b>
1	<b>9/16" HEX WRENCH</b>
2	<b>1/2" HEX WRENCH</b>
1	<b>PLYER</b>
1	<b>PHILLIPS -TYPE</b>

## FASTENERS:

QTY	FASTENER	FOR:
2	<b>5/8 FLAT WASHER</b>	<b>WHEELS</b>
2	<b>COTTER PIN</b>	<b>WHEELS</b>
4	<b>3/8" CARRIAGE BOLT SET</b>	<b>FEED HOPPER</b>
8	<b>1/4" X 1" HEX BOLT SET</b>	<b>WHEELS &amp; BACK SUPPORT</b>
2	<b>1/4" X 3/4" HEX BOLT SET</b>	<b>DISCHARGE HOPPER</b>

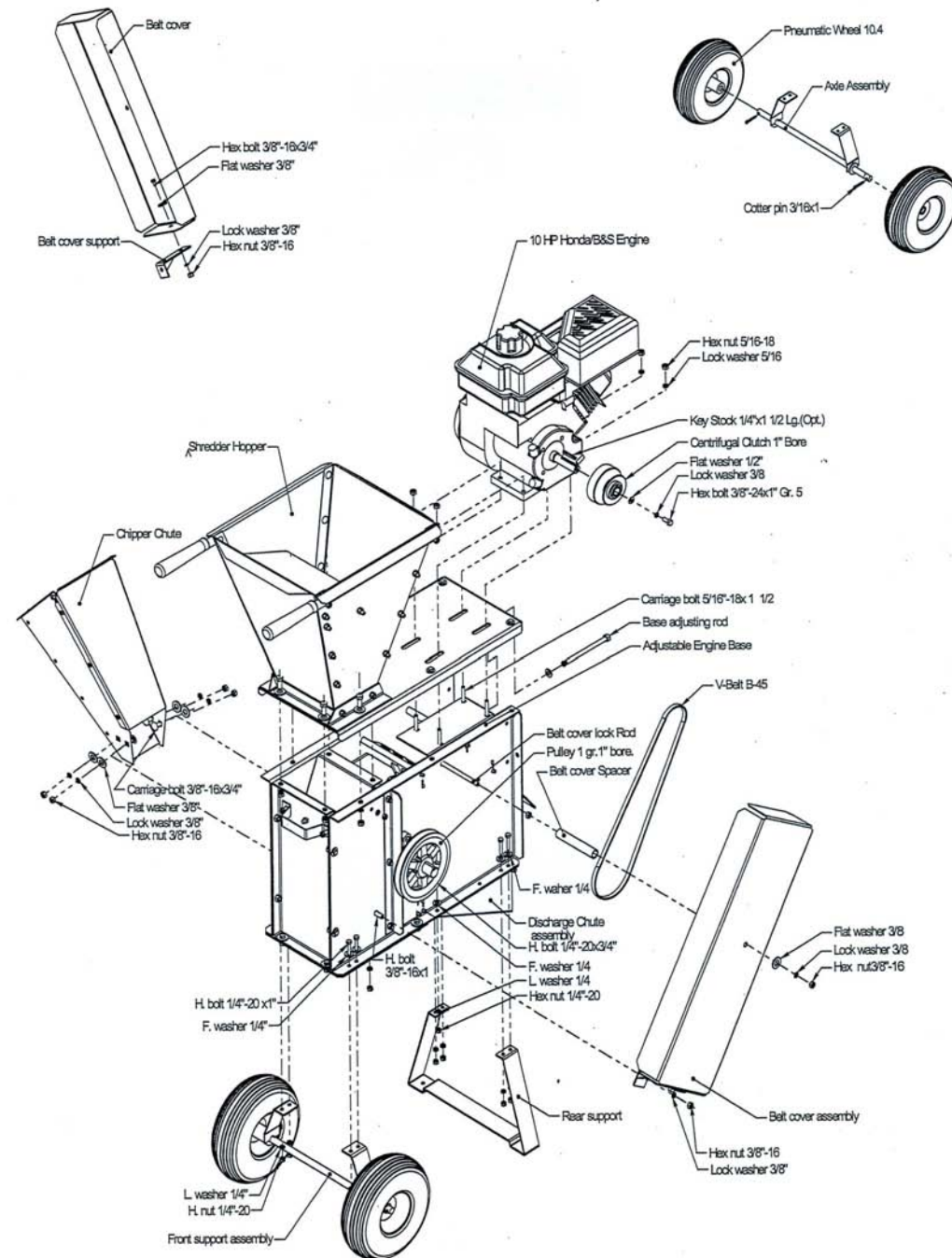

Rederick Metal Industries Corp. | Miami, FL 33142 | Phone : 305-396-3396 |  
 Fax: 305-735-2662 | customer.service@yardbeast.com

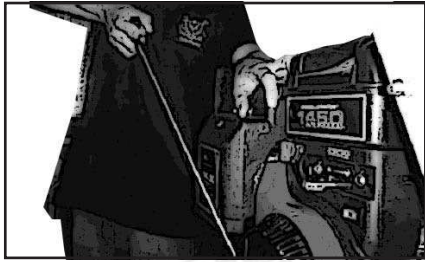

27) Make two to three full swings until the engine starts. Once the engine is running, swiftly move the 'choke lever' to the RUN position. Wait three to four minutes to let the engine lubricate its parts before moving the throttle to full speed.



28) To turn off the engine after use, simply turn the ignition switch OFF and move the throttle back to the 'TURTLE' position and turn the fuel supply knob off.

## UNPACK YOUR YARDBEAST

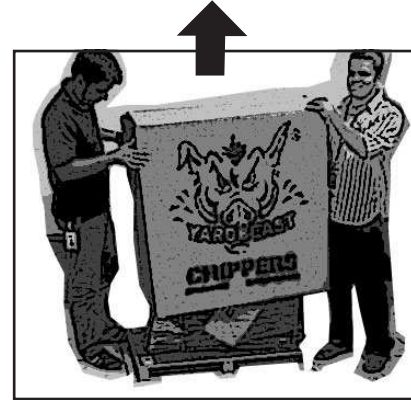

1) First take away protective plastic cover and cut away packing straps and lift the box upwards then.

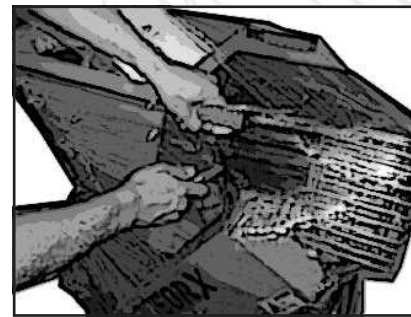

2) With a sharp knife or blade cut away machine's packaging plastic cover. Please be careful when using the knife.

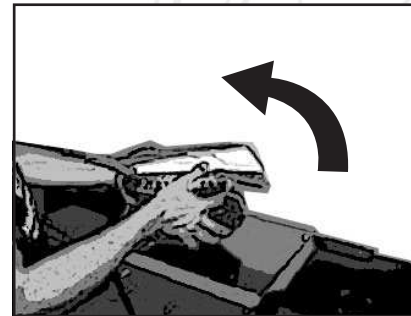

3) Take off the wheels, manuals & fasteners that are stowed into the top hopper and place them nearby.



4) Take the feed hopper off and place it nearby.

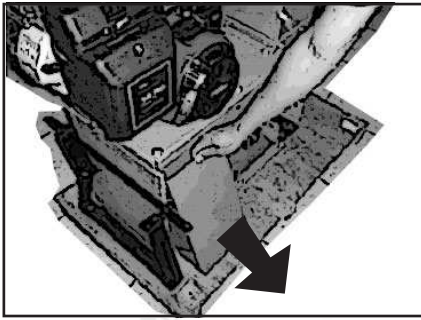

5) Take the discharge hopper and place it nearby.

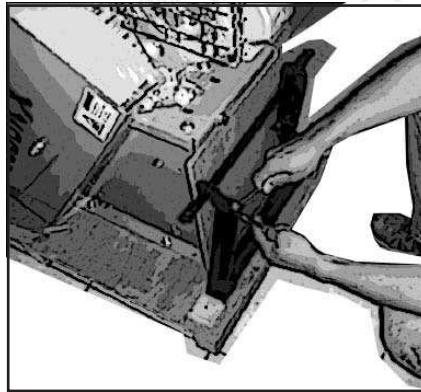

6) Unbolt the wheel base that is attached to the back support for packaging purposes. If bolts are too tight, use two 7/16" hex wrenches.

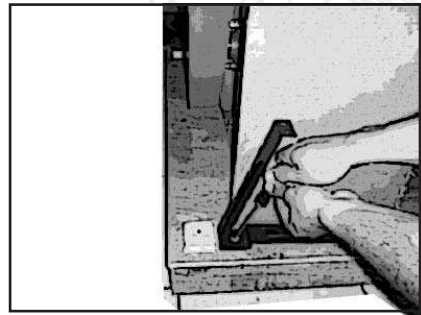

7) Unscrew the back support with a Phillips-type screw.

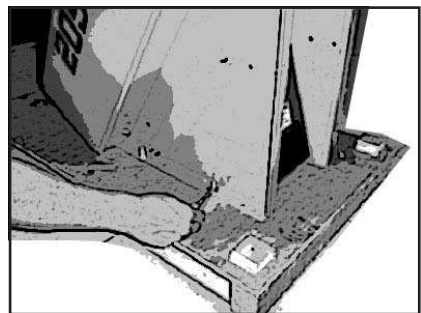

8) The machine comes attached to the wooden support with 4 bolts, 2 by each side. Unbolt then with the help of two 7/16" hex wrenches.

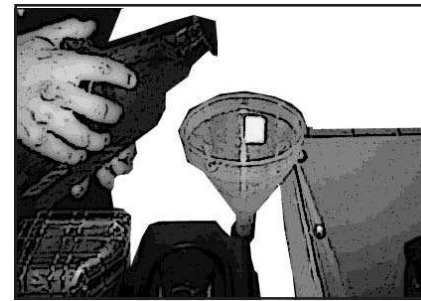

23) Fill with oil.



24) Locate the fuel cap as shown in the picture. Fill with 3 quarts of clean fresh fuel.

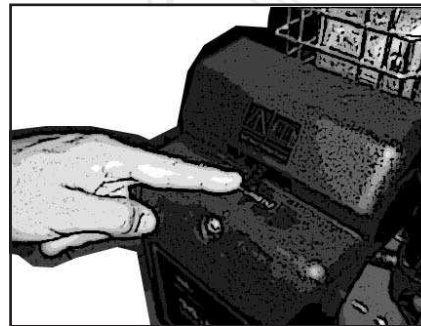

25) Make sure the 'choke lever' is on the CHOKE position.



26) Make sure the ignition switch is on (if available), place the throttle at mid position and put the fuel supply knob in ON position.

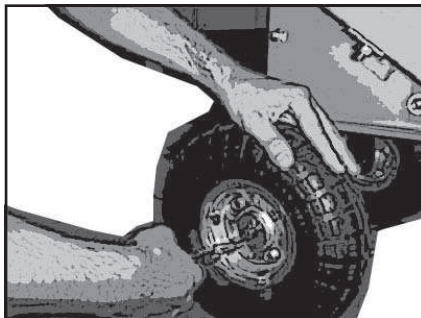

20) Deform the pin's longest leg to make sure the pin will not fall off the unit at any time. You need to use plyers to do this.

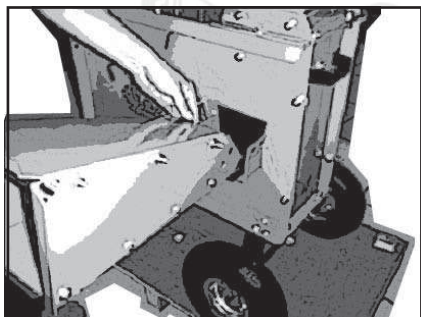

21) Once you are finished assembling the wheels, we will need to assemble the feed hopper. Insert the hopper into its support. Place your hand inside the hopper and push through the 4 - 3/8" x 1" carriage bolts that are supplied with the machine. Tighten with a 9/16" hex wrench. The round head of the bolt goes on the inside of the hopper.

Note: Carriage bolt:

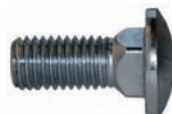

## STARTING YOUR WOOD CHIPPER

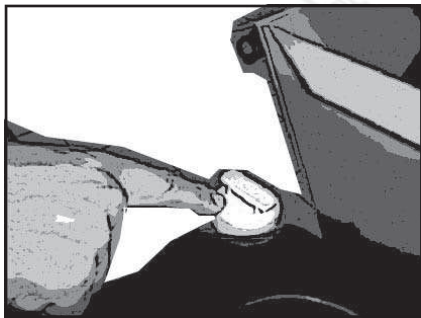

22) Once you have finished assembling your YARDBEAST, we will now proceed to get your engine ready for its first start. Locate the yellow cap on the top part of the engine (as shown in pic), and remove. You should fill with approx. 28oz of fresh SAE 30 oil.

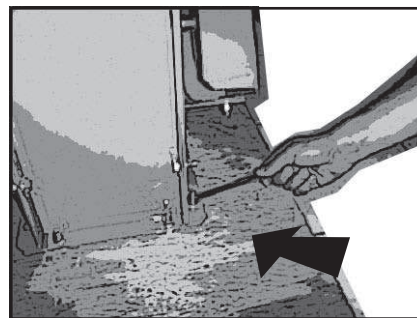

9) Unbolt here. And repeat for the other side.

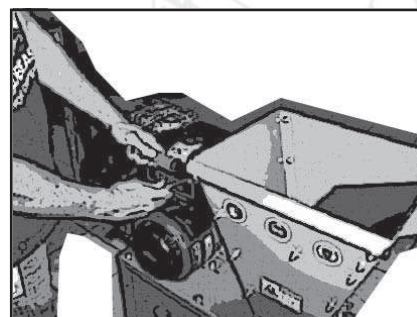

10) Unbolt the handles and flip them 180 degrees as they come in the original way for packaging purposes. If bolts are too tight, please use 1-1/2" hex wrench to get them loose.

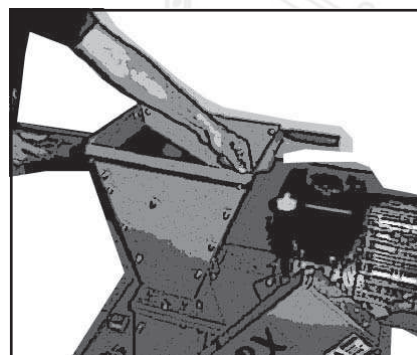

11) Flip the handle and tighten. Repeat for the other side. Use a 1/2" hex wrench for tightening the bolts.

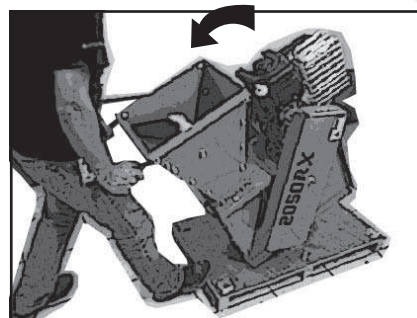

12) Please be careful for this next step. We will tip the unit at the front so we can assemble the wheelbase and the back support. Put your feet on the wooden crate, and with the machine's handle, tip the machine forward. The machine shall be seated on the floor.

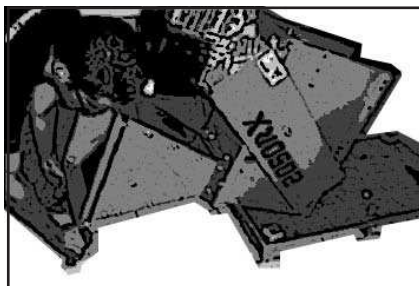

13) Place the machine carefully on the floor. Although this operation can be accomplished by one person, if you are unsure to do this next step by yourself, please ask another person to assist you.



14) Once the machine is placed on the floor, please proceed to assemble the wheelbase and tighten with 4 - 1/4" x 1" hex bolts with their flat washer, spring washer and nut.

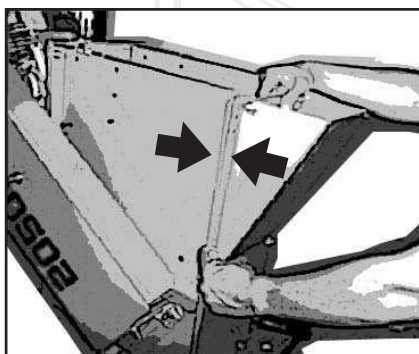

15) Take the discharge hopper and place it as shown on the picture. Place two to three bolts to locate the discharge hopper. Don't put the nuts yet.

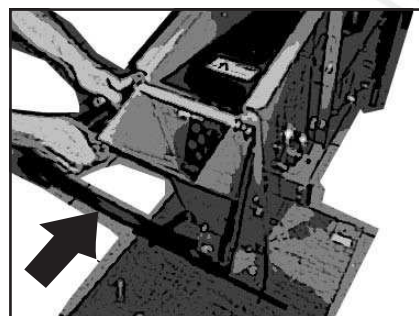

16) Locate the back support's holes on the same location as the discharge hopper's and make them fit through the bolts. Screw in the spring washers of nuts and tighten. You will need 2 - 7/16" hex wrenches for this operation.

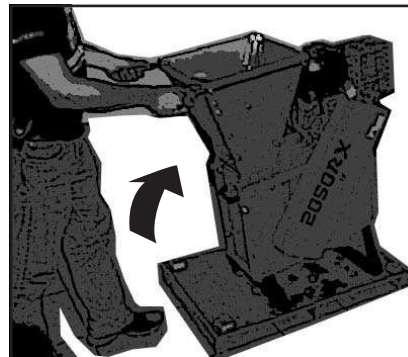

17) Once you tightened the wheelbase and the back support, lift the unit up and carefully place it on the wooden crate. Although this operation can be accomplished by one person if you are unsure to do this by yourself, ask someone to assist you with this step.

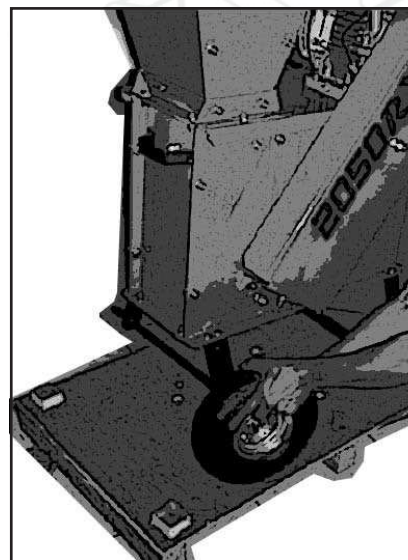

18) Ask another person to help you lift the unit. While the person is lifting the unit, place one wheel on one of the shafts. Repeat for the other side.

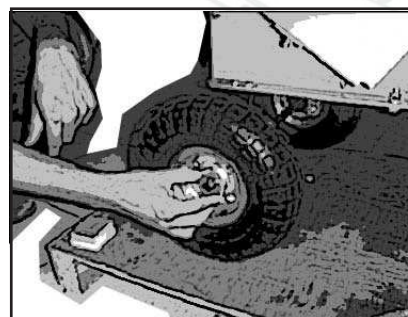

19) Insert a 5/8" flat washer and then secure it by inserting a cotter pin through the shaft bore at the end of the shaft.