

# POWER KING<sup>®</sup>

5" 14HP Chipper Shredder

4" 9.5HP Chipper Shredder

MODEL PK0915 (5") / PK0903 (4")



## OWNER'S MANUAL AND OPERATIONS GUIDE



**WARNING:** This product can expose you to chemicals including benzene, carbon monoxide, and lead which is known to the State of California to cause cancer and birth defects or other reproductive harm. For more information go to [www.P65Warnings.ca.gov](http://www.P65Warnings.ca.gov).

# General Safety Rules

---



Read this Safety & Operating Instructions manual before using your Power King Chipper Shredder. Become familiar with the operation and service recommendations to ensure the best performance from your machine. If you have any questions or need assistance, don't hesitate to give us a call at 1-800-344-3371 or send us an E-mail at [support@qvtools.com](mailto:support@qvtools.com).

## Safety Instructions

The machine must not be used in any other way than described in the manual.

Use only original equipment and spare parts. If you use non-approved spare parts, there is an increased risk and this is, therefore, not permissible. All liability is renounced in the event of an accident or other damage caused by the use of non-approved parts.

Before using the machine for the first time, read and follow this manual

Check Emergency Stop Switch before each operation.

Make sure all bolts and nuts are properly tightened before operation.

Choose a flat work place. Machine can only be used outdoors, away from flammable materials.

User must wear close fitting work clothes, work gloves, eye protectors, ear plugs, dust proof mask and work boots.

Before and after using the machine, proper maintenance is necessary.

Failure to comply with these safety instructions could result in personal injury and/or damage to product or property.

## Protecting Yourself and Those Around You

---

### **WARNING**

This is a high-powered machine, with moving parts operating with a high amount of energy. You must operate the machine safely. Unsafe operation can create a number of hazards for you as well as anyone else in the vicinity. Always take the following precautions when using this machine:

- Keep in mind that the operator is responsible for accidents or hazards occurring to other people, their property, and themselves
- Always wear protective goggle / safety glasses with side shields while using the chipper to protect your eyes from debris
- Avoid wearing loose clothing or jewelry, which can catch on moving parts
- We recommend wearing gloves. Be sure your gloves fit properly and do not have loose cuffs or drawstrings
- Wear steel toed boots with non-slip treads. Do not use machine while barefoot or with open toed sandals
- Wear long pants / jeans
- Keep bystanders at least 50 feet away from your work area at all times. Stop the engine when another person or pet approaches.

## Safety for Children and Pets

---

### **WARNING**

Tragic accidents can occur if the operator is not alert to the presence of children and pets. Children are often attracted to the machine and the operation of the unit. Never assume that children will remain where you last saw them. Always follow these precautions.

- Keep children and pets at least 50 feet from the working area and ensure they are under the watchful care of a responsible adult.
- Be alert and turn the machine off if children or pets enter the work area.
- Never allow children to operate the chipper.

# Safety with Gas Powered Engines

---



Gasoline is a highly flammable liquid. Gasoline also gives off flammable vapor that can be easily ignited and cause a fire or explosion. Never overlook the hazards of gasoline. Always follow these precautions:

- Never run the engine in an enclosed area or without proper ventilation as the exhaust from the engine contains carbon monoxide, which is an odorless, tasteless, and a deadly poisonous gas.
- Store all fuel and oil in containers specifically designed and approved for this purpose and keep away from heat and open flame, and out of reach of children.
- Fill the gasoline tank outdoors with the engine off and allow the engine to cool completely. Don't handle gasoline if you or anyone nearby is smoking, or if you're near anything that could cause it to ignite or explode. Reinstall the fuel tank cap and fuel container cap securely.
- If you spill gasoline, do not attempt to start the engine. Move the machine away from the area of the spill and avoid creating any source of ignition until the gas vapors have dissipated. Wipe up any spilled fuel to prevent a fire hazard and properly dispose of the waste.
- Allow the engine to cool completely before storing in any enclosure. Never store a machine that has gas in the tank, or a fuel container, near an open flame or spark such as a water heater, space heater, clothes dryer, or furnace.
- Never make adjustments or repairs with the engine running. Shut down the engine, disconnect the spark plug wire, keeping it away from the spark plug to prevent accidental starting, wait 5 minutes before making adjustments or repairs.
- Never tamper with the engine's governor setting. The governor controls the maximum safe operation speed and protects the engine. Over revving the engine is dangerous and will cause damage to the engine and to the other moving parts of the machine. The engine's governor setting has been preset by the factory.
- Keep combustible substances away from the engine when it is hot.
- Never cover the machine while the muffler is still hot.
- Do not operate the engine with the air cleaner or the carburetor air intake cover removed. Removal of such parts could create a fire hazard. Do not use flammable solutions to clean the air filter.

- The muffler and engine become very hot and can cause severe burns. DO NOT TOUCH!

### A Note to all Users

No list of warnings and cautions can be all-inclusive. If situations occur that are not covered by this manual, the operator must apply common sense and operate the chipper in a safe manner.

## Mechanical Specifications

Model	PK0915 (5")	PK0903 (4")
Engine	14HP CH440 Kohler engine	9.5HP CH395 Kohler Engine
Chipping Fineness	Granulated Detrital	Granulated Detrital
Function	Chipping leaves, branches, crop stray, farming feed, etc.	Chipping leaves, branches, crop stray, farming feed, etc.
Max Blade Speed	2530r/min	2530r/min
Fuel Type	87 Octane Unleaded Gas	87 Octane Unleaded Gas
Chipper Weight	397lbs	387lbs
Shipping Weight	451lbs	441lbs
Shipping Dimensions	45"x26"x44"	45"x26"x44"

## Chipper Operation

---

### NOTICE

All branches should not exceed 5in (PK0915)/ 4in (PK0903) diameter. Fresh cut branches and straw are recommended for best performance. Due to different hardness and moisture content, the engine may struggle but will continue to chip. Proper insertion of branches is large diameter to smaller diameter. It is best to put branches with leaves all together. Small logs are not recommended.

## Procedure

---

1. Make sure chipper is on flat dry surface.
2. Adjust exit chute to location for processed material.
3. Refer to Kohler manual on how to start the engine.
4. Adjust throttle to maximum RPM.
5. Do not stand directly behind entry chute. **Stand to the side of entry chute as material may kick back.**
6. Load material from large diameter side.
7. When machine starts to auto-feed, let go of branch.
8. Let it completely process material before adding more.
9. If machine does not auto-feed, you may need to slowly load the branches or use other branches to guide it in.

## Maintenance

---

Regular maintenance is the way to ensure the best performance and long life of your machine. Please refer to this manual for proper maintenance procedures.

### WARNING

**Before performing any maintenance procedure or inspection, stop the motor, unplug the spark plug and wait 5 minutes to allow all parts to cool. Disconnect the spark plug wire to prevent accidental startup.**

**Important Setup Notes**

Our unit does NOT have a GEAR REDUCTION SYSTEM as noted in the Kohler manual. This engine does not need OIL for a GEAR REDUCTION SYSTEM.

Unit does NOT come with oil. There may be left over residue from factory testing but is not enough to run the engine.

We recommend 10W-30 Motor Oil and the engine holds 1.2quarts.

Both Yellow Oil Fill Holes go to the same reservoir. Use whichever is easiest to reach.

Make sure all bolts are snug before running.

**Maintenance Checklist**

PROCEDURE	Before each use	Every 5 hours	Every 25 hours	Every 100 hours
Check engine oil level	Δ			
Check general equipment	Δ			
Grease bearings				Δ
Check belts	Δ			
Clean engine exterior and cooling		Δ		
Change engine oil	First time 5hours		Δ	
Replace air filter			Δ	
Replace spark plug				Δ

**Engine Service**

Refer to the engine manufacturer’s user manual for engine maintenance.

**Lubrication**

We recommend 1 pump of lithium grease in each flange bearing before each season of use.

**Blades**

Check blades for any cracks, dullness or chips. If there are any cracks, do not use until they have been replaced. If the blade shows dullness or chips, these blades can be reversed.

The blades can be removed by using the included T-bar wrench or a 17mm Socket with extension and ratchet driver. Make sure to use scrap wood or any soft material in the drum to prevent it from moving. If the drum moves, you may strip the bolts. Also, use rags or paper towel in the entry to prevent bolts or blades from falling into the drum.

### **Bar Blade**

The bar blade is located at the bottom of the drum housing towards the entry chute. It creates a gap for the chipping blades and creates a scissor action. If you have poor chipping performance, we recommend adjusting this by loosening the bolts underneath, adjusting the bar blade to about 1-5mm to the chipping blades, make sure it is parallel to the chipping blades and retighten.

### **Jams**

Stop the machine, remove both entry chute and exit chute. Remove the cap on the bearing and turn the shaft using the included wrench. You can also use a larger adjustable wrench if more force is needed. Try rotating in both directions to loosen jammed material.

### **Easy Open Chutes**

The machine features a latch mechanism for easy opening of the chutes. This provides faster and toolless access to the drum area for clearing out debris or blade changing.



# Troubleshooting

<b>SYMPTOM</b>	<b>POSSIBLE CAUSE</b>
<p>The engine won't start.</p> <p>(Please refer to the engine user manual for engine-specific procedures.)</p>	<ul style="list-style-type: none"> <li><input type="checkbox"/> Is the ignition switch in the "ON" position?</li> <li><input type="checkbox"/> Is the fuel shut-off valve on?</li> <li><input type="checkbox"/> Are you using fresh, clean gas? If the gas is old, change it. Use a fuel stabilizer if you keep gas longer than 30 days.</li> <li><input type="checkbox"/> Is the spark plug clean? If the spark plug is dirty or cracked, change it. If it's oily, leave it out, hold a rag over the plug hole and pull the recoil cord several times to blow out any oil in the cylinder, then wipe off the plug and reinsert it.</li> </ul>
<p>The engine lacks power or is not running smoothly.</p> <p>(Please refer to the engine user manual for engine-specific procedures.)</p>	<ul style="list-style-type: none"> <li><input type="checkbox"/> Check that the Throttle Lever is in the "Run" position.</li> <li><input type="checkbox"/> Is the air filter clean? If it's dirty, change it following the procedure in the engine manufacturer's owner's manual.</li> <li><input type="checkbox"/> Is the spark plug clean? If it's fouled or cracked, change it. If it's oily, leave it out, hold a rag over the plug hole and pull your recoil cord several times to blow out any oil in the cylinder, then wipe off the plug and reinsert it.</li> <li><input type="checkbox"/> Are you using fresh, clean unleaded gas? If it's old, change it. Use a fuel stabilizer if you keep gas longer than 30 days.</li> <li><input type="checkbox"/> Does your engine have the right amount of clean oil? If it's dirty, change it following the procedure in the engine manufacturer's owner's manual.</li> <li><input type="checkbox"/> Check the oil level and adjust as needed.</li> </ul>
<p>Engine smokes.</p> <p>(Please refer to the engine user manual for engine-specific procedures.)</p>	<ul style="list-style-type: none"> <li><input type="checkbox"/> Check the oil level and adjust as needed.</li> <li><input type="checkbox"/> Check the air filter and clean or replace if needed.</li> <li><input type="checkbox"/> You may be using the wrong oil—too light for the temperature. Refer to your Engine Owner's Manual for detailed information.</li> <li><input type="checkbox"/> Clean the cooling fins if they're dirty.</li> </ul>
<p>Engine stops while chipping</p>	<ul style="list-style-type: none"> <li><input type="checkbox"/> Check if the engine is stopped by overloading.</li> <li><input type="checkbox"/> Check if something is blocked in the chutes.</li> <li><input type="checkbox"/> check the emergency stop button and protection switch.</li> </ul>
<p>Drum is jammed</p>	<ul style="list-style-type: none"> <li><input type="checkbox"/> Stop the machine, remove both entry chute, exit chute, cap on bearing, and turn the shaft to force the material out. You can use the included wrench or use a larger adjustable wrench for more force.</li> </ul>
<p>Poor chipping performance</p>	<ul style="list-style-type: none"> <li><input type="checkbox"/> Check the gap between bar blade and chipping blades. We recommend 1-5mm of clearance for best performance.</li> </ul>

# Assembly

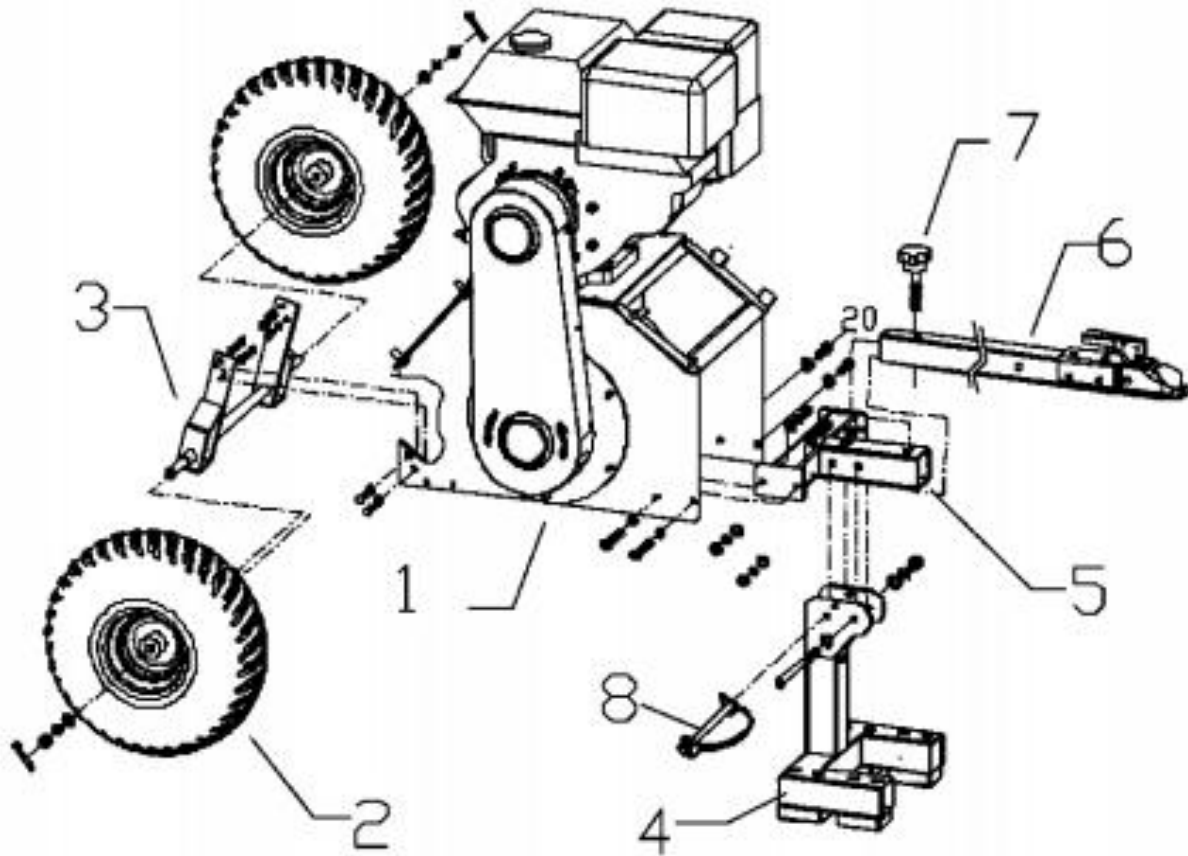

Number	1	2	3	4	5	6	7	8
Part	Drum Housing	Wheel	Axle Stand	Support Leg	Tow Bar Joint	Tow Bar	Locking Knob	Safety Pin

## Installation Procedure:

1. Lay the Drum Housing (1) on a small platform. Make sure it has space on the sides for installation of the wheels (2) and support leg (4).
2. Attach wheels (2) to axle stand (3) and use the proper nuts to secure.
3. Attach wheels (2) with axle stand (3) to the drum housing (1) using proper bolts and nuts.
4. Install the tow bar joint (5) to drum housing (1) using proper bolts and nuts.
5. Attach support leg (4) to tow bar joint (5) using bolt and nut and safety pin (8).
6. Tow bar (6) attaches to tow bar joint (5) and use locking knob (7) to secure.
7. Remove from platform.

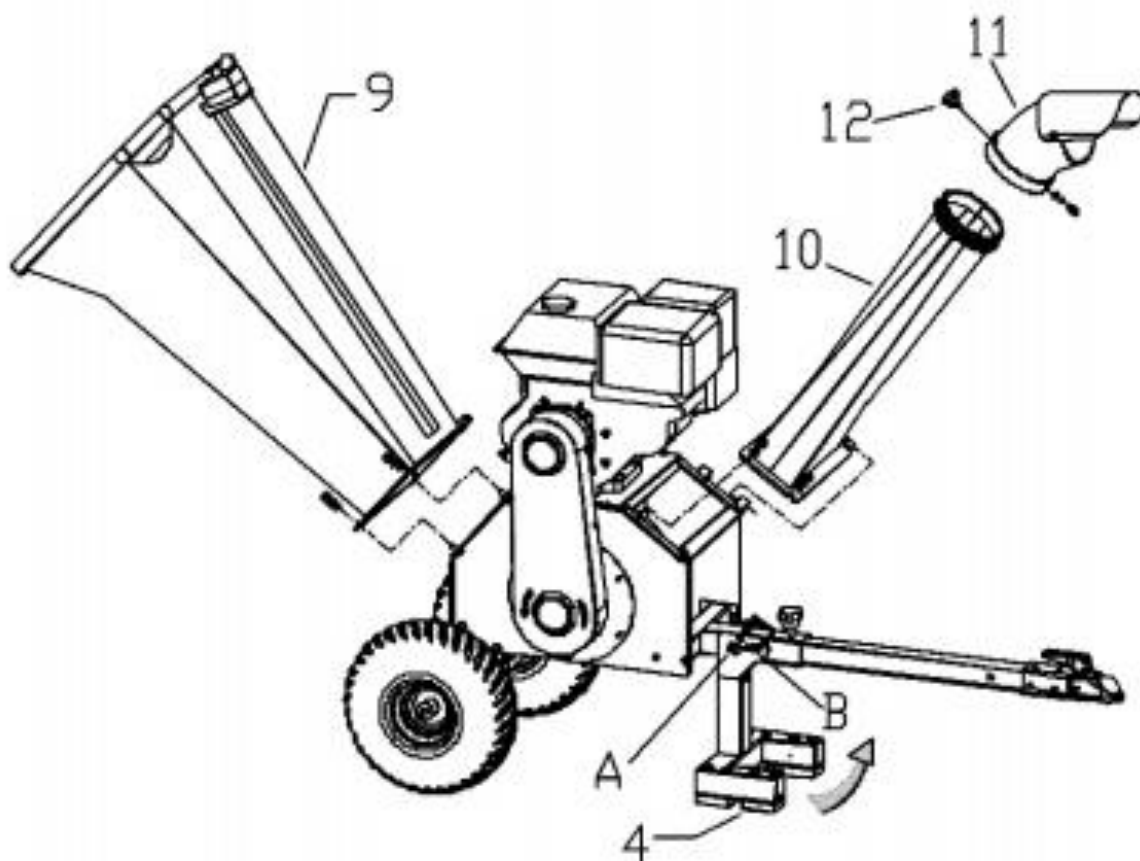

Number	9	10	11	12
Part	Entry Chute	Exit Chute	Adjustable diverter	Set Knob

10. Attach the hinge of the entry chute (9) to the hinge on the drum housing (1). Use latch mechanism to secure.
11. Attach the hinge of the exit chute (10) to the hinge on the drum housing (1). Use latch mechanism to secure.
12. Attach adjustable diverter (11) to top of exit chute (10) and use set knob (12) to secure.

# Parts Diagram

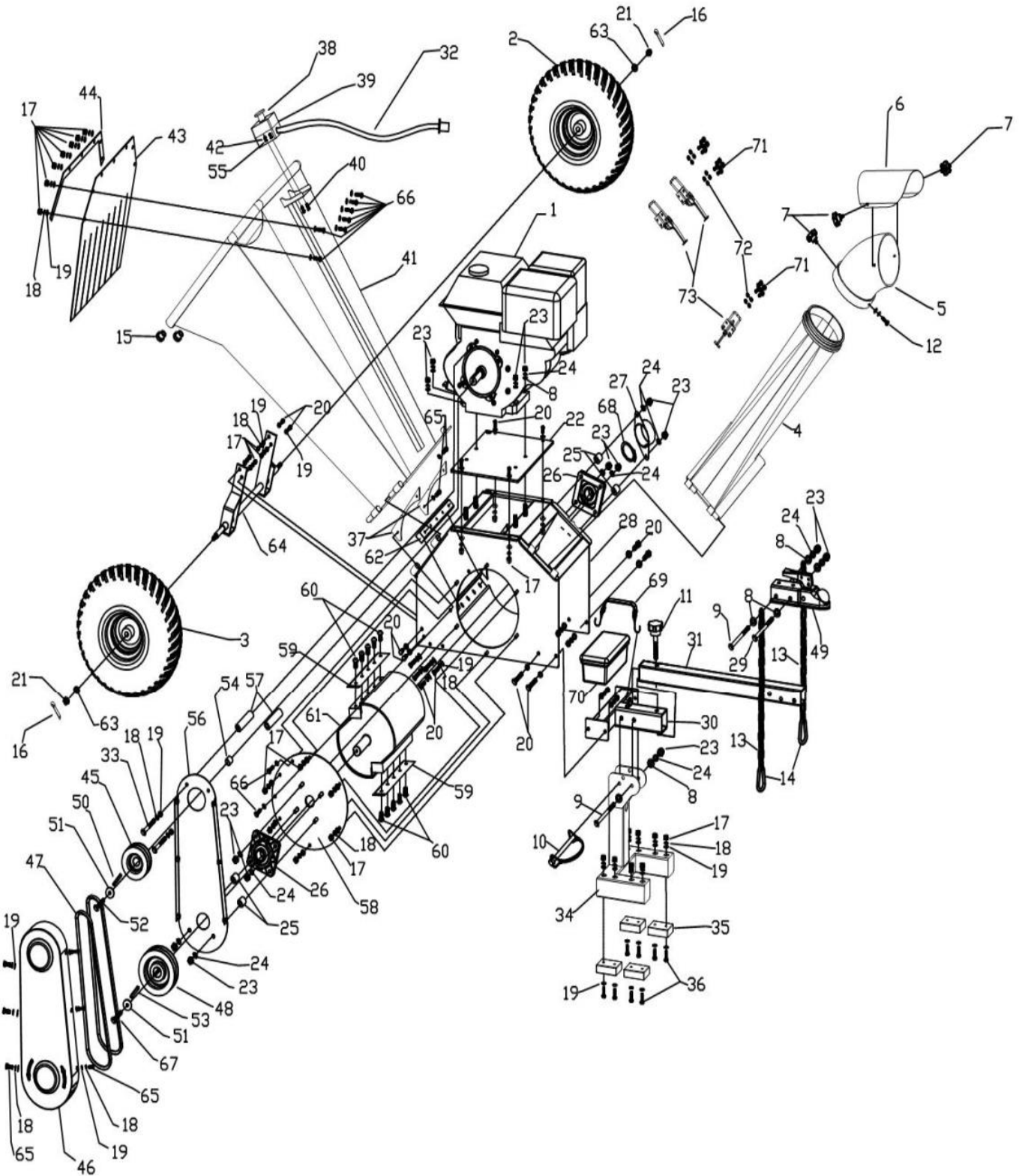

part No.	description	part No.	description
1	engine	38	safety switch
2	left tire	39	switch box
3	right tire	40	bolt
4	Lower part of exit chute	41	feed chute
5	Upper part of exit chute	42	lock nut
6	exit chute diverter	43	protect sheet
7	knob	44	protect sheet plate
8	washer	45	small pulley
9	bolt	46	belt cover
10	D-pin	47	belt
11	knob	48	big pulley
12	bolt	49	hitch trailer
13	chain	50	key
14	Buckle	51	washer
15	plug	52	bolt
16	D-pin	53	key
17	lock nut	54	pulley sleeve
18	spring washer	55	washer
19	washer	56	belt plate
20	bolt	57	bushing
21	lock nut	58	bearing block plate
22	plate for engine	59	blade
23	lock nut	60	bolt
24	spring washer	61	drum
25	bushing	62	bottom blade
26	bearing with block	63	washer
27	bearing block cap	64	axle
28	crush room	65	bolt
29	bolt	66	bolt
30	Connecting Tube	67	bolt
31	tow bar	68	Shaft ring
32	Wire Harness	69	rubber binding hook
33	bolt	70	tool box
34	support foot	71	bolt
35	rubber	72	spring washer
36	bolt	73	faster clip
37	Baffle plate		

## WARRANTY POLICY

Thank you for choosing QV TOOLS Products. We're here to ensure that your experience is perfect. In some rare instances, you may need some help with a warranty claim.

**Please call us at 1-800-344-3371.**

Product must be registered to activate the warranty. Warranty registration is below. Warranty begins from date of purchase.

### Engine Warranty

Kohler engines are covered with a 3-year commercial and 3-year residential warranty for Command Pro series. Parts and Labor are covered as well. Power King engines by Lifan are covered with a 1-year residential warranty. Visit your engine manufacturer for warranty details or visit [www.QVTools.com](http://www.QVTools.com).

### Equipment Warranty

Manufactures defects of chassis and component parts are covered for 1 year. Only parts are covered. Shipping cost is not covered.

QV Tools will replace any part that is proven to be defective in material or workmanship. This warranty is not valid for products or parts affected or damaged by accident, collision, normal wear, fuel contamination, abuse, neglect, misuse, alteration and/or unsuitable use or unauthorized parts. Transportation charges to and from service centers, if assigned, is not covered. Shipping cost of product for repair is not covered. Labor to repair equipment is not covered. Consumable parts such as brake pads, tires, racks, splines, grinding teeth, blades, bar blades, etc. are not covered under warranty. Power King has all replacement parts at value pricing.

### Damaged Products

You must take the time to inspect the goods before you sign the delivery receipt from the carrier. If you sign the delivery receipt without inspecting the shipment, you will be responsible for filing a freight claim and arranging for a repair or return of the damaged goods.

Concealed damage claims must be reported immediately.

### Suspected Damage

On occasion, the outer carton may look damaged, but the product inside the box is perfectly fine. If you suspect concealed damage, notate **"Possible Freight Damage" on the delivery receipt while the driver is present. This way, if you discover later that the product is damaged, the remedy of a freight claim is less of a hassle.**

### Obvious Damage

Do not sign for damaged products. If your product arrives damaged, **please (a) REFUSE DELIVERY and (b) Call where you purchased the item Immediately so the dealer can process the appropriate claims and coordinate an exchange for you.**

### Defective Products

We encourage you to test your product within 15 days of receipt so we can quickly remedy any mechanical problems. If you think your product is defective, **call QVTools at 1-800-344-3371**. In most cases, it's a simple issue that can be resolved over the phone. We have expert technicians standing by to help resolve your issue. Please have your model number and serial number available and your proof of purchase receipt for faster service.

### Original Owner Warranty

Warranty is non-transferable and covers the original owner only who purchased from a QVTOOLS authorized dealer.